

HEADING	
Title:	CoastKey Yamaha Installation
Doc. Nr:	NWS021-30
Author:	Pål Sørensen
Issue date:	16-04-2020

HISTORY				
Issue number	Date	Version	Owner	Approved by
1	16-04-2020	A	Pål Sørensen	
2				
3				

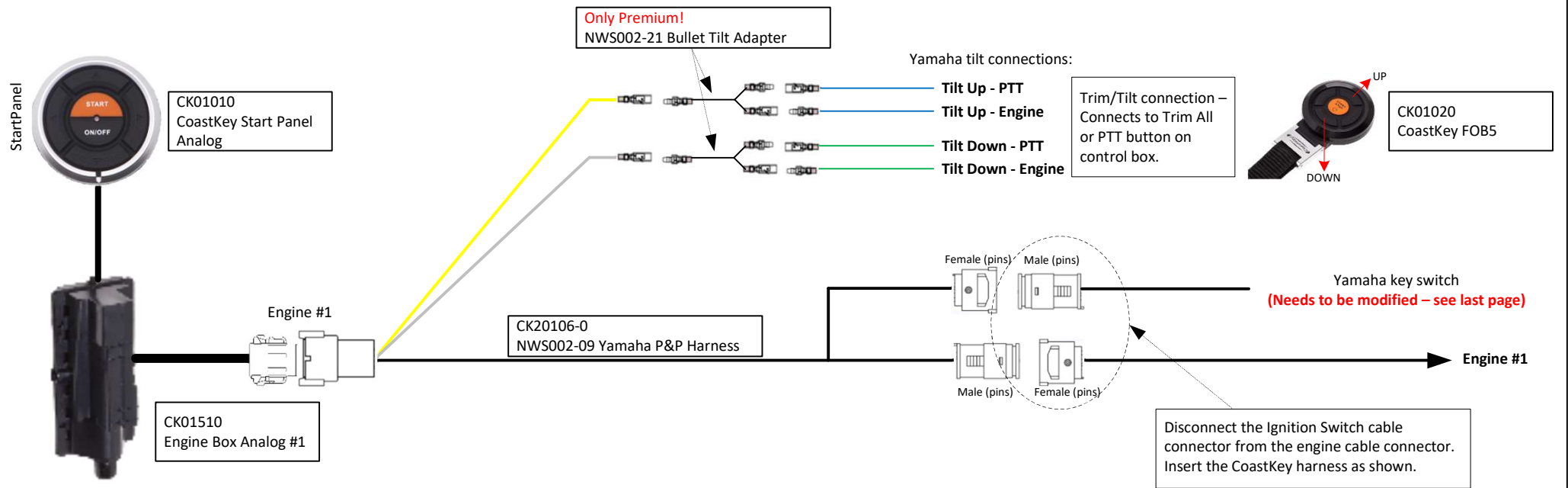

Date	Drawn by	Scale
16-04-2020	Pål Sørensen	-
Item name		
CoastKey Yamaha Installation Single (Mechanical) – CoastKey Basic, Standard and Premium		
Item number		Rev.
NWS021-30		A

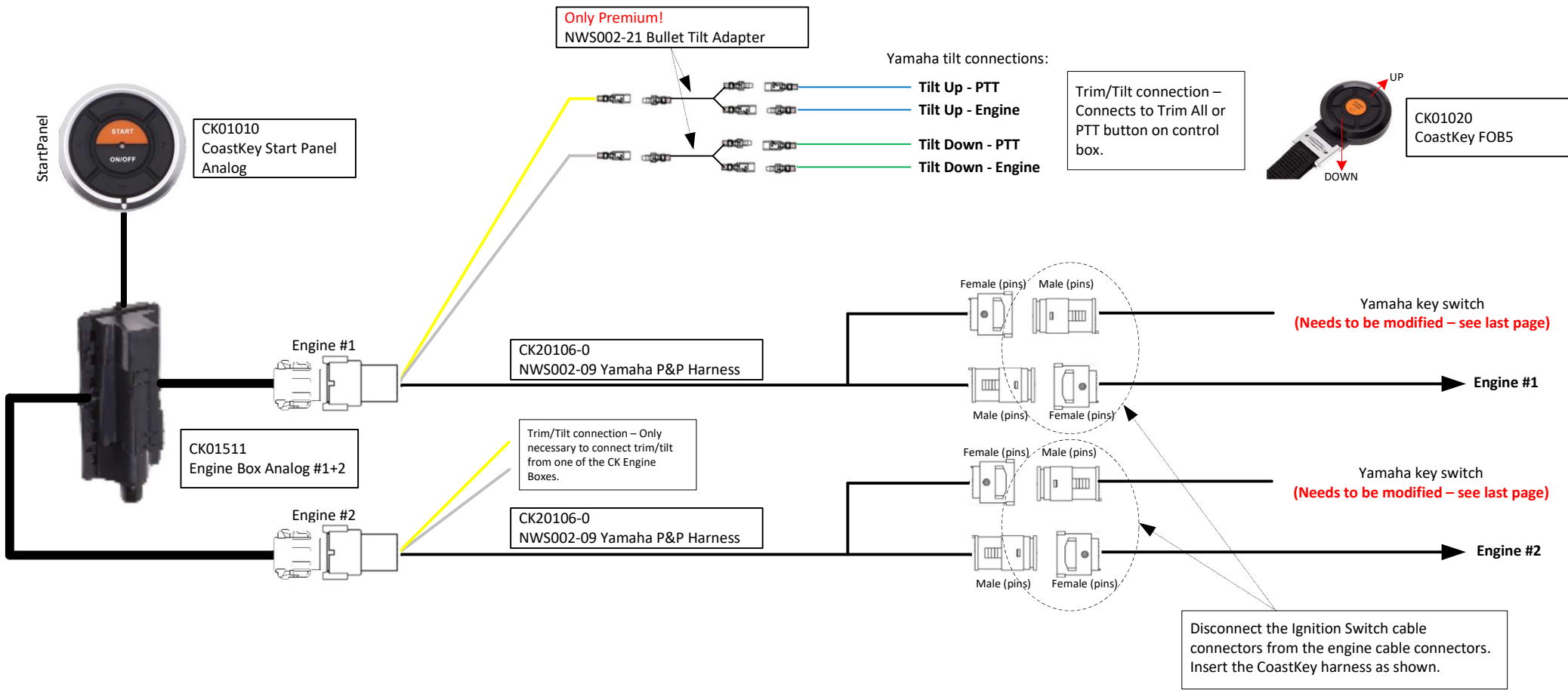

Date	Drawn by	Scale
16-04-2020	Pål Sørensen	-
Item name		
CoastKey Yamaha Installation Twin (Mechanical) – CoastKey Basic, Standard and Premium		
Item number		Rev.
NWS021-30		A

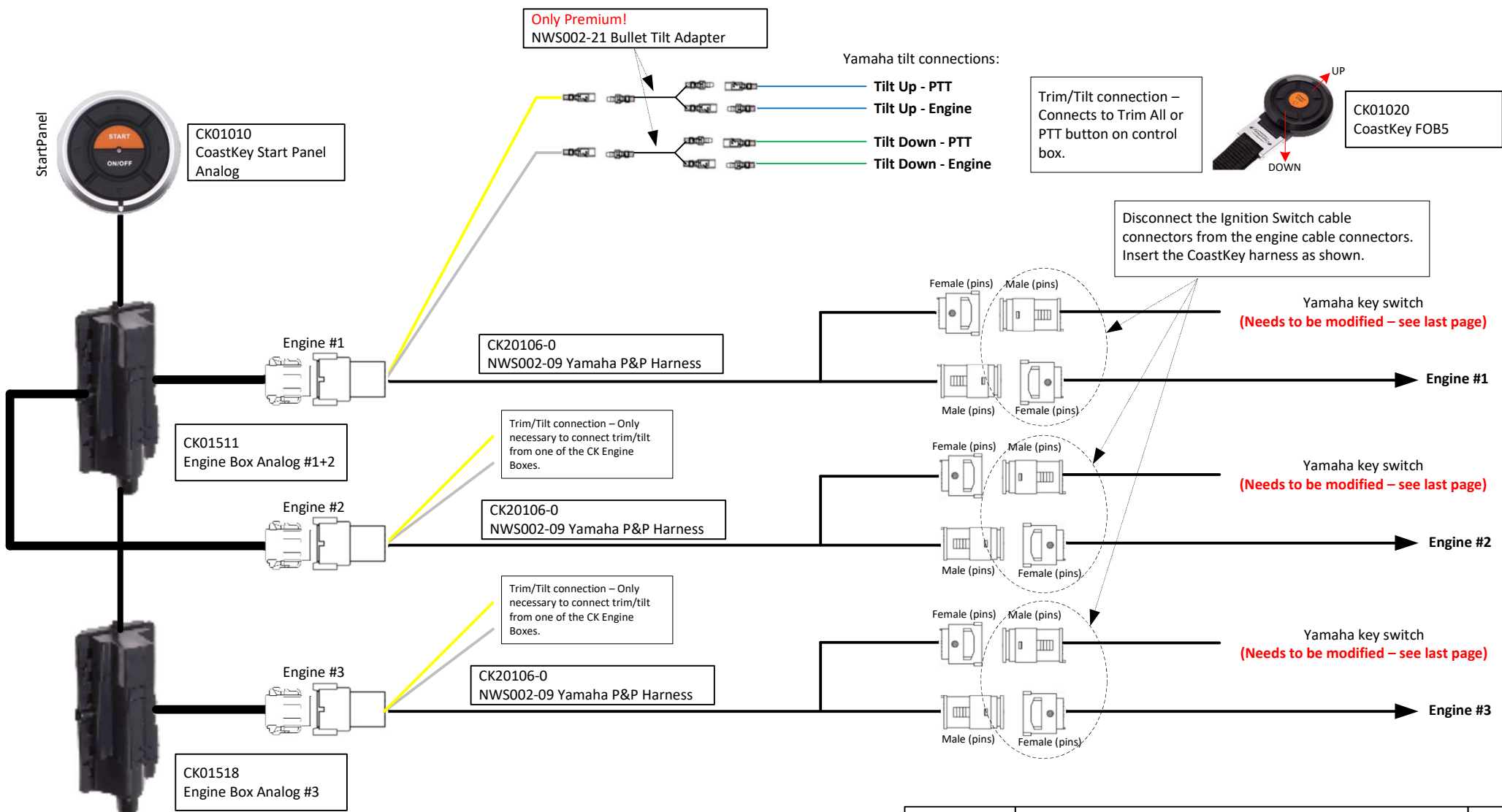

Date	Drawn by	Scale
16-04-2020	Pål Sørensen	-
Item name		
CoastKey Yamaha Installation Triple (Mechanical) – CoastKey Basic, Standard and Premium		
Item number		Rev.
NWS021-30		A

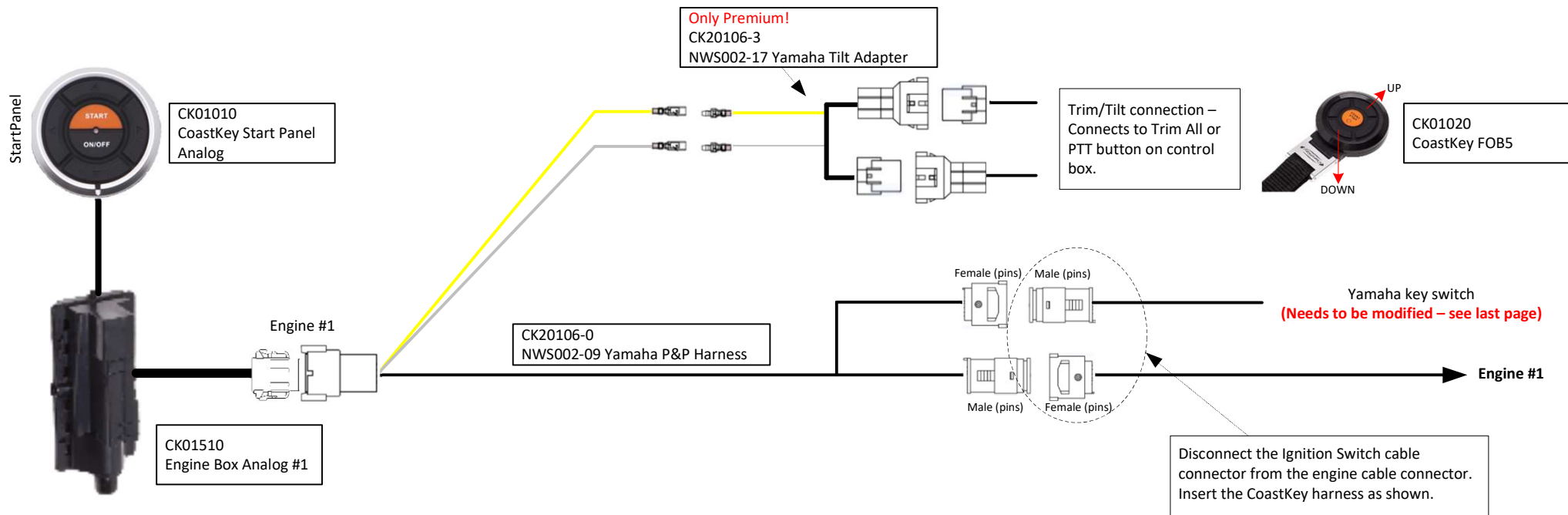

Date	Drawn by	Scale
16-04-2020	Pål Sørensen	-
Item name		
CoastKey Yamaha Installation Single (DBW) – CoastKey Basic, Standard and Premium		
Item number		Rev.
NWS021-30		A

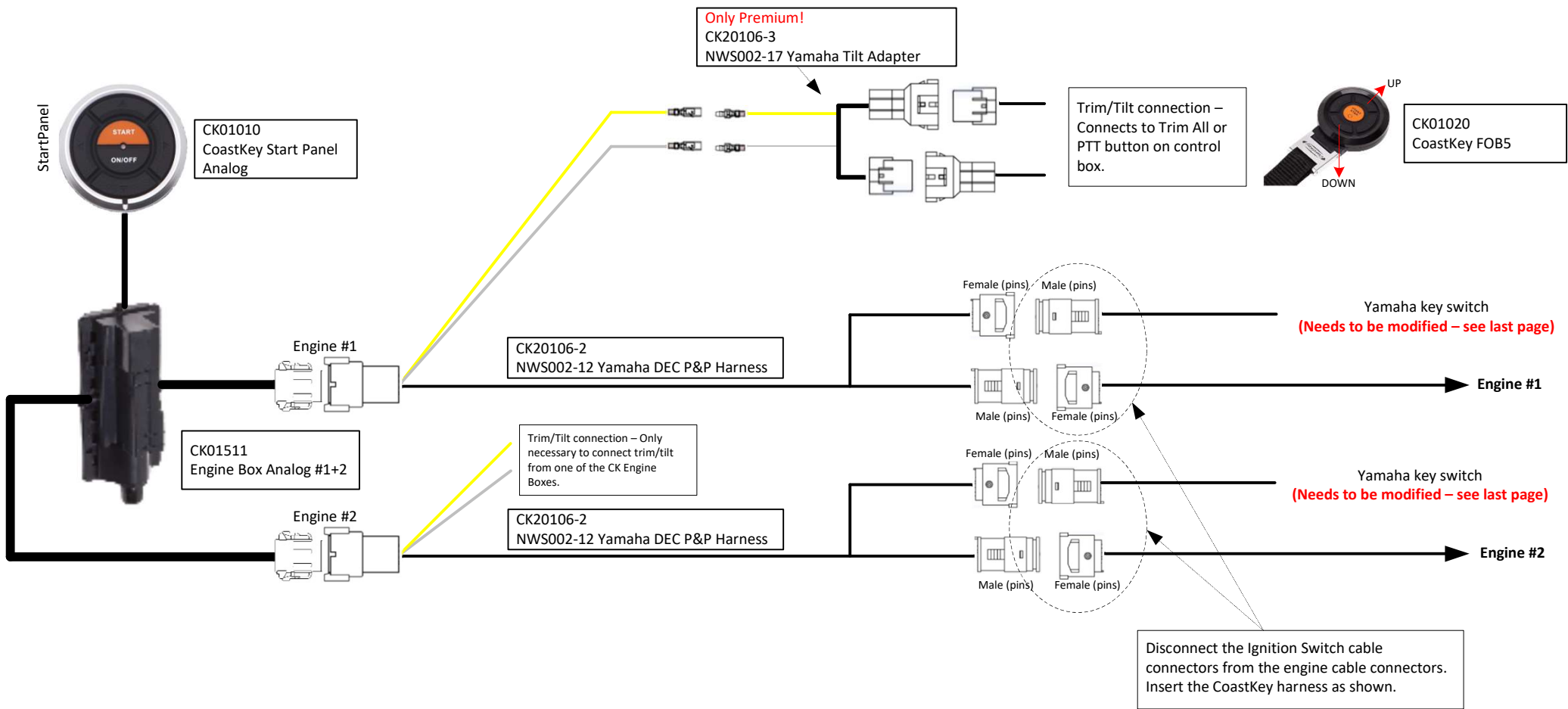

Date	Drawn by	Scale
16-04-2020	Pål Sørensen	-
Item name		
CoastKey Yamaha Installation Twin (DBW) – CoastKey Basic, Standard and Premium		
Item number		Rev.
NWS021-30		A

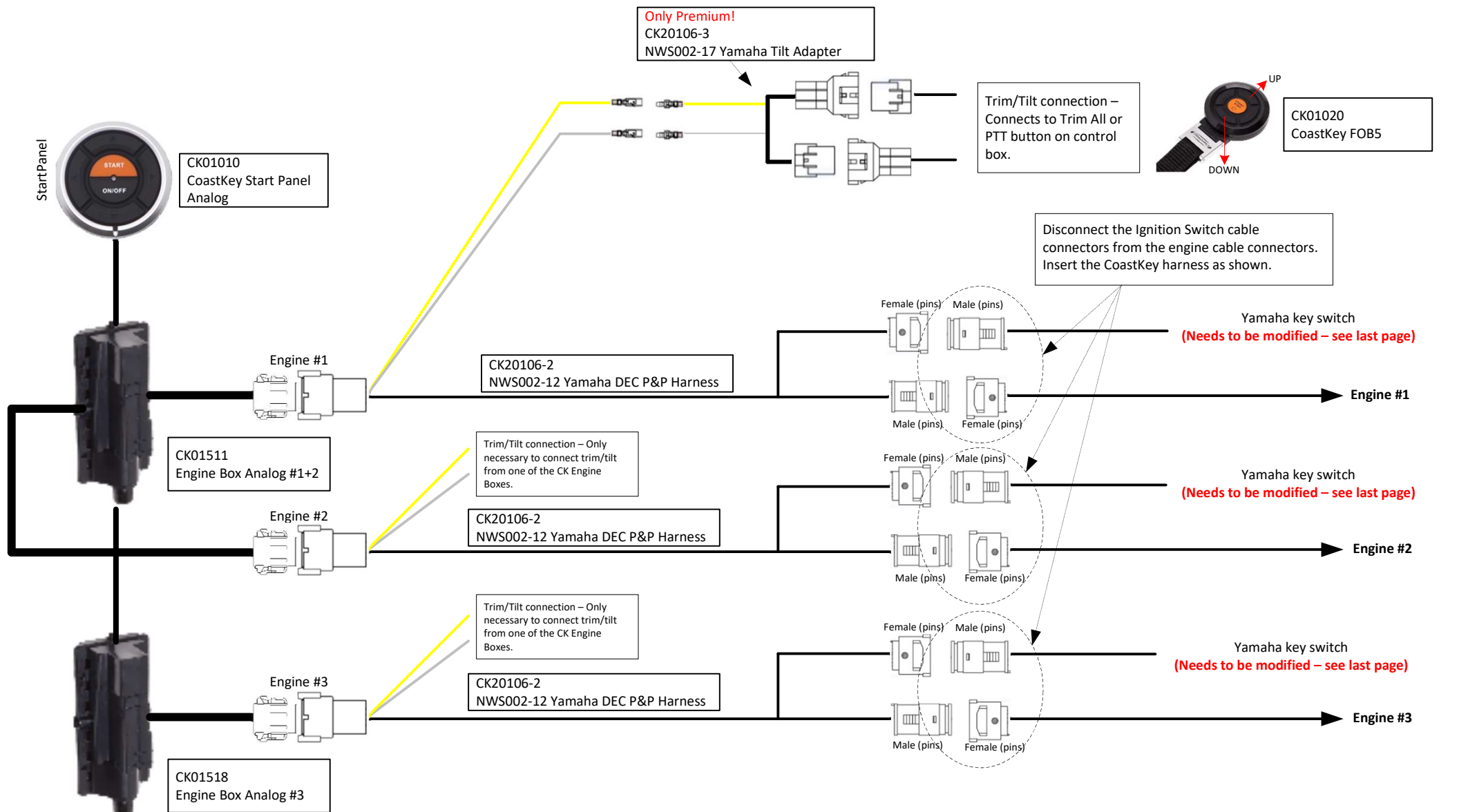

Date	Drawn by	Scale
16-04-2020	Pål Sørensen	-
Item name		
CoastKey Yamaha Installation Triple (DBW) – CoastKey Basic, Standard and Premium		
Item number		Rev.
NWS021-30		A



Modification of Ignition Key Switch!

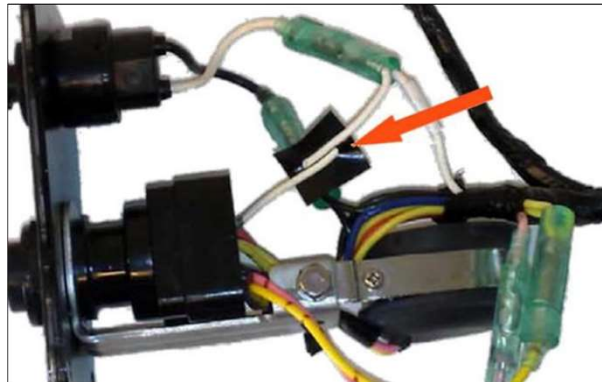
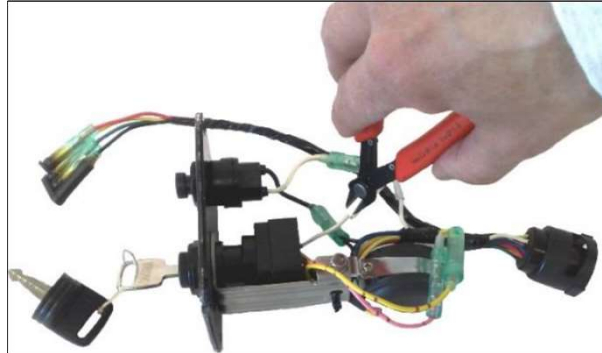

NOTE!

If the key switch is being used, find the white wire from the ignition switch. This wire ends up in a split.

Cut the white wire between the ignition switch and the split. A good rule is to cut it about 20mm from the ignition switch, then it is possible to repair it later. Isolate both of the loose wire ends.

Date	Drawn by	Scale
16-04-2020	Pål Sørensen	-
Item name		
CoastKey Yamaha Ignition Switch Modification (DBW and Mechanical)		
Item number		Rev.
NWS021-30		A